

This product was designed and manufactured in the U.S.A. by:

**Philips Burton**

11500 Melrose Avenue  
Franklin Park, IL 60131  
U.S.A.

Tel.: (800) 444-9909

Fax: ((800) 765-1770

Web: [www.burtonmedical.com](http://www.burtonmedical.com)

EU Authorized Representative:

**Philips Healthcare Nederlands B.V.**  
PMS Quality & Regulatory Affairs  
Veenpluis 4-6  
5684 PC Best  
The Netherlands



## OUTPATIENT® II & COOLSPOT® II

FloorStand, Wall & Ceiling Versions

Installation Instructions

**PHILIPS**  
**burton**

**Warranty Information:**

For complete, detailed information on your specific product's warranty coverage, please visit:  
<http://www.burtonmedical.com/wp-content/themes/burtonmedical/literature/warranty.pdf>

## Introduction

Congratulations on your purchase of an Outpatient<sup>®</sup> II / Coolspot<sup>®</sup> II Philips Burton medical light!

The light(s) are designed to give the professional health care market superior performance, reliability and value. The lights contain advanced optical and mechanical solutions intended to offer you an optimal working environment for efficient and comfortable procedures, while assisting in enhancing performance.

### Outpatient<sup>®</sup> II

The bulbs in the Outpatient<sup>®</sup> II are wired in parallel to ensure continuous operation in the event that one or two bulbs burn out. Heat filters and dichroic coatings ensure a cool light beam, and an air-circulating fan helps maintain cool interior lighthead temperatures.

Focus is changed by means of a central, removable, and autoclavable handle. It can be removed with one hand to protect sterile procedures. The handle accepts sterile, disposable covers.

Power to the fixture is controlled from a switch on the extension arm for ceiling models, and a base-mounted foot switch for floor models. The wall model has a switch near the cord inlet on the fixture. Effective working distance between patient and lighthead is from 0.6 to 1 meter. A central, removable and autoclavable handle also accepts pre-sterilized covers.

The floorstand model incorporates a footswitch, locking casters, and cord wrap. A friction knob at the top of the upright allows the user to quickly secure the self-balancing arm, preventing accidental movement or drift. When installed according to manufacturer's recommendations, ceiling and wall-mounted systems will meet California Seismic Codes.

The Outpatient<sup>®</sup> II is designed and assembled in the USA and classified/tested by a Nationally Recognized Testing Laboratory (NRTL). Low voltage operation of the bulbs minimizes electrical hazards. 100V, 120V, 230V or 240V input is standard. The Outpatient<sup>®</sup> II meets the medical light standards of IEC/UL 60601-1 and 60601-2-41.

### CoolSpot<sup>®</sup> II

The lighthead incorporates an aperture-control wheel and an intensity-control wheel. An intensity switch ("Hi/Lo") is located on the yoke. The bulb provides approximately 600 hours life on the standard intensity ("Lo") setting. A double heat filtration system keeps the beam cool, and an air-circulating fan helps maintain cool interior lighthead temperatures.

A removable, autoclavable handle is incorporated in the lighthead. To facilitate sterile procedures, this handle can be removed or replaced with one hand, and it accepts disposable sterile covers.

The floorstand model incorporates a footswitch, locking casters, and cord wrap. A friction knob at the top of the upright allows the user to quickly secure the self-balancing arm, preventing accidental movement or drift. When installed according to manufacturer's recommendations, ceiling and wall-mounted systems will meet California Seismic Codes.

The CoolSpot<sup>®</sup> II is designed and assembled in the USA and classified/tested by a Nationally Recognized Testing Laboratory (NRTL). 100V, 120V, 230V or 240V input is standard. The CoolSpot<sup>®</sup> II meets the medical light standards of IEC/UL 60601-1 and 60601-2-41.

Power to the fixture is controlled from a switch on the extension arm for ceiling models, and a base-mounted footswitch for floor models. The wall model has a switch near the cord inlet on the fixture. Effective working distance between patient and lighthead is from 0.6 to 1 meter. A removable and autoclavable handle also accepts pre-sterilized covers.

## Intended Use:

The Outpatient® II / Coolspot® II medical examination light is intended to provide illumination of body surfaces and cavities during a medical examination.

Please read the installation instructions very carefully, and follow the safety instructions and requirements.

If there are any particular problems that have not been treated in sufficient detail in these instruction manuals, please contact your supplier for your own safety.

This manual contains guidance on how to use & maintain the light(s).

Philips Burton Medical recommends using qualified personnel for mechanical/electrical installation. Failure to use qualified personnel may invalidate the warranty of the product due to improper installation.

Philips Burton Medical is a leading manufacturer of medical lighting. The product lines encompass lights for procedure, examination and surgery applications. You are welcome to find out more on our web site at [www.burtonmedical.com](http://www.burtonmedical.com).

The following models are covered in this manual:	120V 60Hz	230V/240V 50Hz International	230V/240V 50Hz Europe
OP II Floor	OP216FL	OP225FL	O202FL
OP II Wall	OP216W	OP225W	O202W
OP II Single Ceiling	OP216SC	OP225SC	O202SC
OP II Double Ceiling	OP216DC	OP225DC	O202DC
CS II Floor	CS316FL	CS325FL	C302FL
CS II Wall	CS316W	CS325W	C302W
CS II Single Ceiling	CS316SC	CS325SC	C302SC
CS II Double Ceiling	CS316DC	CS325DC	C302DC
OPII / CS II Combo Ceiling Mount	OC516CC	OC525CC	~

### 7.1.1 External Surfaces (weekly, or as needed – unplug or turn off the fixture first)

- External surfaces of the Outpatient® II and CoolSpot® II fixtures are polycarbonate, ABS, and/or powder-painted aluminum or steel. Suggested cleaning technique is to use a soft cloth and mild soap and water. Do not let any water solution run into the arm or lighthouse. After cleansing, dry all surfaces promptly with a soft cloth or towel.
- For especially stubborn external stains, isopropyl alcohol can be used. Under no circumstances should organic solvents such as paint thinners, MEK, or acetone be used.
- Every 100 hours of typical use, open the lighthouse and blow out the loose dust. Use a damp cloth or swab to clean out remaining dirt, especially in the grill areas. Clean the lenses and exterior of the light with a mild detergent or alcohol solution.

### 7.1.2 Handle Sterilization

- Outpatient® II: The central, single-post handle may be removed for cleaning and sterilization (autoclave). Push in the locking rod to release handle. To reinstall a sterilized handle, locate the machined flat surface facing the locking rod and push the handle in until it bottoms out. Twist the handle until it clicks (~ ¼ turn). Replacement Handle OPII PN 1008465.
- CoolSpot® II: The single-post handle on the lighthouse can be sterilized (autoclaved) and re-attached without touching the lighthouse. Simply unscrew the handle to remove it. Replacement Handle CSII PN 1008466B.

### Sterilization Protocol:

- Place the handle in the autoclave.
- Set the autoclave cycle for 270°F (132°C) pre-vacuum cycle.
- Set the cycle time for 3 minutes, turn the sterilizer on, and wait for the process to be completed.
- Remove the handle and place it in use, or transport and store it in a sterile environment pending use.

### Hygiene and Disinfection:



Hospital, clinic, and office protocols generally are based on CDC and other National Committee guidelines for hygiene and disinfection. The user of this equipment should follow these guidelines to eliminate or minimize the risks of cross-contamination and infection.




**NOTE:** Disposable handle covers are an available option for both models; order using Philips Burton part number 0008100PK (25 pack).

## 7.0 Maintenance



(Refer to maintenance manual for further detail)

<b>WARNING</b> 	The proposed maintenance schedule is a suggestion. Depending on the use of the product and the operating environment, the required maintenance may not be limited to this. It is the responsibility of the user to service and maintain the product as needed. Failure to do so may present risk of serious or fatal injury.
<b>WARNING</b> 	If the equipment is not functioning properly, do not attempt “quick fixes” with tape, wires etc. If the solution cannot be found in this manual Philips Burton should be contacted.

Component	OPII	CSII
Bulb Types	<b>PN 0006130PK</b> (3/Box)	<b>PN 0007006PK</b> (4/Box)
Fusing	<b>PN 4000025</b> Floor, wall, double ceiling mounts: (2 fuses) T 3 A, 250V, 5x20mm  Single ceiling mount: (1 fuse) T 3 A, 250V, 5x20 mm	<b>PN 4000025</b> Floor, wall, double ceiling mounts: (2 fuses) T 3 A, 250V, 5x20mm  Single ceiling mount: (1 fuse) T 3 A, 250V, 5x20 mm

<b>CAUTION</b> 	To avoid damage to equipment or reduce bulb life use only bulbs recommended by Philips Burton.
--	--

### 7.1 Cleaning

<b>WARNING</b> 	Electrical shock. For all cleaning work, power off the equipment and secure it from being switched on again. Make sure cleaning fluids do not run into the equipment.
<b>CAUTION</b> 	Damage to equipment. Apart from mild detergents and isopropyl alcohol, no other cleaning agents or chemicals should be used on the product.

## Table of Contents

1.0 Safety Instructions.....	7
1.1 Symbols .....	7
1.2 Safety Precautions.....	7
2.0 Floor Stand Model .....	8
2.1 Pre-Assembly.....	8
2.2 Assembly .....	8
3.0 Wall Mount Model .....	13
3.1 Pre-Assembly.....	13
3.2 Assembly .....	13
4.0 Single Ceiling Mounts.....	18
4.1 Pre-Assembly.....	18
4.2 Assembly.....	18
5.0 Double Ceiling Mounts.....	26
5.1 Pre-Assembly.....	26
5.2 Assembly.....	26
6.0 Anchorage and Seismic.....	32
7.0 Maintenance .....	36
7.1 Cleaning.....	36
Wiring Diagrams .....	See Instructions for Use and Maintenance Manual
Warranty .....	39
Philips Burton Information .....	40

## Unpacking and Inspection

Carefully unpack the cartons and match the parts received with the parts list enclosed.

Before Reporting Shortages:

Be sure you have received the correct number of boxes, cartons, etc., as shown on the bill of lading.

Check the entire shipment against the enclosed packing slip.

Items indicated in the column headed "Back Order" are not included in the shipment and will follow later.

Be sure that nothing has been removed from the cartons before they are checked by the individual in charge.

Empty all boxes completely, open all inside containers, and examine all packing material to ensure small articles are not overlooked.

If a Shortage or Damage Occurs:

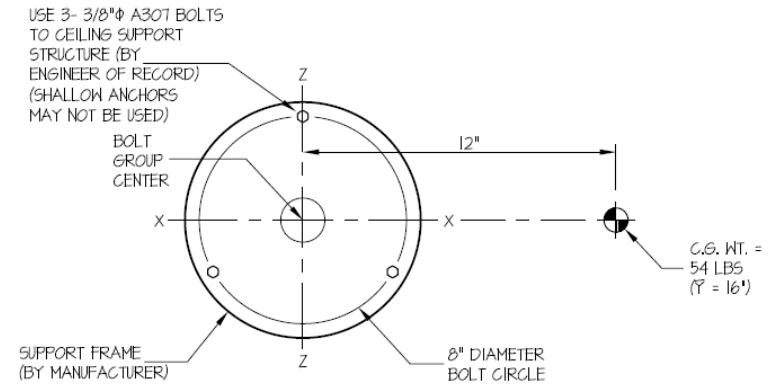
1. You, the receiver, not Philips Burton, is responsible for filing any claim(s) with the delivering carrier within five (5) days after receipt of the shipment.
2. If damage or shortage occurs in transit, the delivering carrier is required by law to make notation of a shortage or damage. This notation is to be made on the bill of lading.
3. If, in your opinion, there may be concealed damage, an agent from the delivering carrier is obligated to make an inspection after the goods are unpacked.
4. Do not destroy packing material until after the agent has made out his report.
5. All claims must be made to the carrier, not Philips Burton.
6. Written authorization must be obtained from Philips Burton before merchandise can be returned.

## Ceiling Mount

<b>EASE EQUIPMENT ANCHORAGE &amp; SEISMIC ENGINEERING</b> www.equipmentanchorage.com		
<b>BURTON MEDICAL PRODUCTS</b>	DES. J. ROBERSON	SHEET <b>2</b>
<b>COOLSPOT/OUTPATIENT MINOR SURGERY/ DIAGNOSTIC LIGHTS</b>	JOB NO. 11-1138	OF <b>2</b> SHEETS
	DATE 6/3/11	

SEISMIC ANCHORAGE

CEILING MOUNTED



PLAN AT CEILING

### LOADS:

WEIGHT = 54 LBS  
HORIZONTAL FORCE ( $E_h$ ) = 194 LBS  
VERTICAL FORCE ( $E_v$ ) = 22 LBS

### BOLT SPECS: 3/8" A307 BOLTS:

$T_{ALLOW} = 3600$  LBS/BOLT  
 $V_{ALLOW} = 1910$  LBS/BOLT

### BOLT GROUP PROPERTIES:

$I_{X-X} = 24$  in.<sup>4</sup>  
 $I_{Z-Z} = 24$  in.<sup>4</sup>  
 $I_{Y-Y} = 48$  in.<sup>4</sup>

### MOMENTS:

$M_{XX} = 194\#(16") + (1.2(54\#) + 22\#)12" = 4145$  #"  
 $M_{ZZ} = 194\#(16") + (1.2(54\#) + 22\#)12" = 4145$  #"  
 $M_{YY} = 0$  # (UNIT IS FREE TO ROTATE 360 DEGREES AROUND Y-Y AXIS)

### BOLT FORCES:

TENSION (T)

$$T = \frac{4145\#(4\#)}{24} + \frac{1.2(54\#) + 22\#}{3} = 720 \text{ LBS/BOLT (MAX)}$$

SHEAR (V)

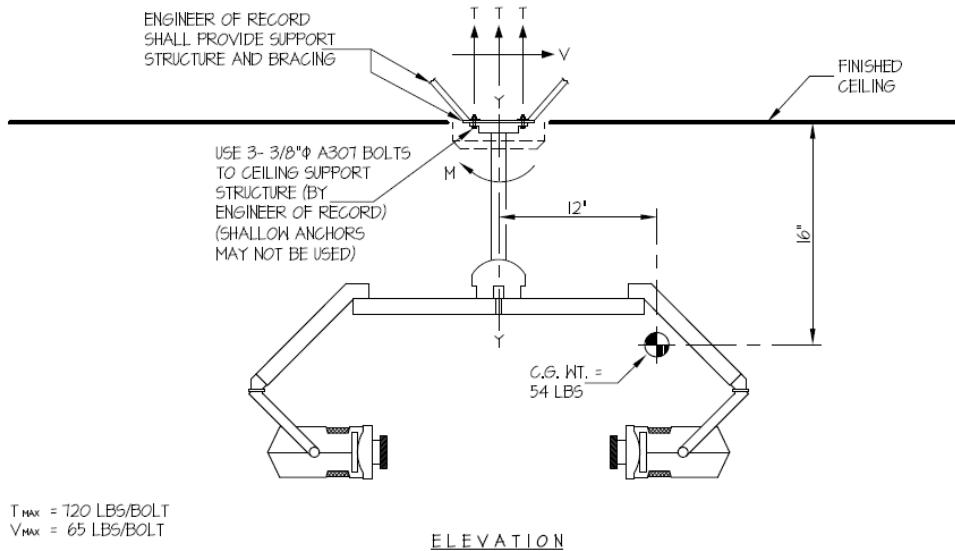
$$V = \frac{194\#}{3} = 65 \text{ LBS/BOLT (MAX)}$$

## Ceiling Mount

<b>EASE EQUIPMENT ANCHORAGE &amp; SEISMIC ENGINEERING</b> www.equipmentanchorage.com		
<b>BURTON MEDICAL PRODUCTS</b>	DES. J. ROBERSON	SHEET <b>1</b>
<b>COOLSPOT/OUTPATIENT MINOR SURGERY/ DIAGNOSTIC LIGHTS</b>	JOB NO. 11-1138	OF <b>2</b> SHEETS
	DATE 6/3/11	

SEISMIC ANCHORAGE

CEILING MOUNTED



### NOTES:

1. FORCES ARE DETERMINED PER 2010 CALIFORNIA BUILDING CODE SECTION 1613A AND ASCE 7-05 SECTIONS 12 AND 13. STRENGTH DESIGN IS USED.

HORIZONTAL FORCE ( $E_H$ ) =  $3.60 W_p$  ( $S_{DS} = 2.00, a_p = 2.5, I_p = 1.5, R_p = 2.5$ )  
VERTICAL FORCE ( $E_v$ ) =  $0.40 W_p$

2. CENTER OF GRAVITY (C.G.) WEIGHT IS A MAXIMUM. THIS CALCULATION ENCOMPASSES ALL WEIGHTS UP TO THE MAXIMUM WEIGHT SHOWN.

3. ARCHITECT OR STRUCTURAL ENGINEER OF RECORD SHALL PROVIDE SUPPORT STRUCTURE TO SUPPORT WEIGHTS AND FORCES SHOWN.



## 1.0 Safety Instructions

Please note that assembly of this product must be carried out by a qualified personnel. At some points of assembly you may require the assistance of an additional person.

- Read these assembly instructions carefully before assembling the light fixture. It will protect you and others from potential injuries that may occur.
- Make sure to follow these instructions when assembling. DO NOT modify any parts before, during, or after assembly.
- If problems are encountered when assembling, contact Philips Burton's technical support. The contact information can be found at the end of this manual.
- To avoid electric shock, disconnect all power and remove all fuses prior to assembly.
- These assembly instructions only apply to the products listed here and should not be used for any other products.

### 1.1 Symbols

In these assembly instructions and on the device, important points have been marked with symbols. The symbols have the following meanings:



#### CAUTION

Non-compliance with caution notes may cause injuries or material damage.



#### WARNING

Disregarding this instruction can present the risk of serious or fatal injury.



#### NOTE

Provides usage tips and useful information.



#### ELECTRIC SHOCK

The above is an electric shock warning symbol. Non-compliance with this symbol may result in injuries due to electric shock.

### 1.2 Safety Precautions



#### CAUTION

Failure to properly follow installation and preventive maintenance instructions may result in mechanical failure.



#### WARNING

Before undertaking any work, ensure that the main power is off and secured from accidentally being switched on again.



#### NOTE

This light should only be installed by a qualified personnel.



#### NOTE

It is the responsibility of the customer to make sure the supporting wall / ceiling and the anchoring is safe, adequately strong and in compliance with all applicable building codes. (See Equipment Anchorage Diagrams.)

## 2.0 Floor Stand Model

### 2.1 Pre-Assembly



**WARNING:** Failure to properly follow installation and preventive maintenance instructions may result in mechanical failure.

To avoid an electric shock, please make sure the floor stand is not connected to a power supply when assembling.

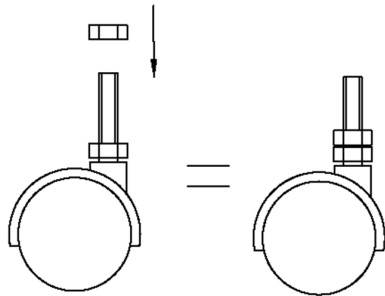
- 2.1.1 Ensure that the intended electrical outlets are 3-prong grounded-type, supplying the appropriate voltage. Each light draws 1.4 amps current (Outpatient® II or CoolSpot™ II) through the primary circuit.
- 2.1.2 **NOTE:** The Burton FlexiMount™ floorstand base and upright have been designed to be used with the Burton Flexible Arm™ lights. These lights are provided as head-and-arm assemblies which are authorized for use only with Philips Burton FlexiMount™ ceiling mount, wall mount or floorstand. Any other use will void the warranty and may cause a safety hazard.

### 2.2 Assembly

Tools required:

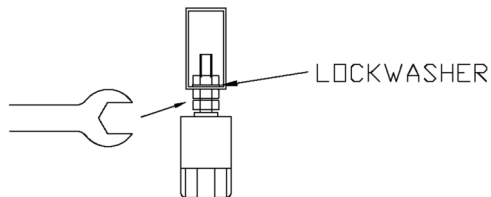
- Allen wrench
- open-end wrenches
- mallet

- 2.2.1 The (4) casters are to be assembled to the base legs. First, run a 5/16" nut all the way down on each stem.



**Figure 1 – Casters  
PN 4000232**

- 2.2.2 Install the casters in the base legs, retaining each caster with a 5/16" nut and lockwasher from inside the leg. Secure each caster by tightening the nut under the leg.



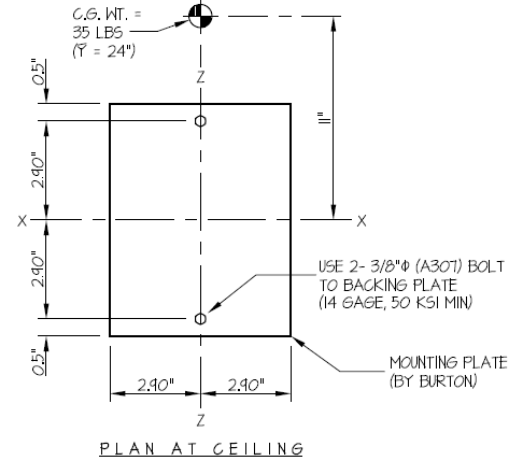
**Figure 2 – Casters in Base**

### Wall Mount

<b>EASE</b> EQUIPMENT ANCHORAGE & SEISMIC ENGINEERING www.equipmentanchorage.com		
<b>BURTON MEDICAL PRODUCTS</b>		DES. <b>J. ROBERSON</b>
<b>COOLSPOT/OUTPATIENT MINOR SURGERY/ DIAGNOSTIC LIGHTS</b>		JOB NO. <b>II-1138</b>
		DATE <b>6/3/11</b>
		SHEET <b>2</b> OF <b>2</b> SHEETS

SEISMIC ANCHORAGE

WALL MOUNTED



2 x STUDS OR 4 x BLKG (DOUGLAS-FIR LARCH NUMBER 2 MIN.) (DESIGNED BY ENGINEER OF RECORD)

USE 4- 3/8"  $\phi$  X 4" LAG BOLTS TO WOOD STUD OR BLKG. (PRE-DRILL HOLES TO SHANK DIAMETER)

5/8" THK. WALL BOARD

WOOD STUD WALL

#### LOADS:

WEIGHT = 35 LBS  
 HORIZONTAL FORCE ( $E_H$ ) = 126 LBS  
 VERTICAL FORCE ( $E_V$ ) = 14 LBS

#### BOLT FORCES:

TENSION (T)

$$T_{\text{VERTICAL}} = \frac{(12(35\#) + 14\#)24"}{1 \text{ SCREW } (5.8")} = 232 \text{ LBS/SCREW}$$

$$T_{\text{PARALLEL}} = 0 \text{ LBS/BOLT (UNIT IS FREE TO MOVE SIDE TO SIDE)}$$

$$T_{\text{PERP.}} = \frac{126\#(13.75")}{1 \text{ SCREW } (5.8")} = 299 \text{ LBS/SCREW}$$

$$T_{\text{MAXIMUM}} = 232\# + 299\# = 531 \text{ LBS/SCREW (MAX)}$$

SHEAR (V) (OCCURS WHEN UNIT IS FLAT AGAINST THE WALL)

$$V_{\text{MAXIMUM}} = \frac{(12(35\#) + 14\#)24"}{(5.8")} + \frac{126\#(13.75")}{(5.8")} = 531 \text{ LBS/SCREW (MAX)}$$

CONCRETE WALL (3000 PSI MIN.) BY ENGINEER OF RECORD

USE 4- 3/8" HILTI KB-TZ EXPANSION ANCHORS (MIN. EMBED. ( $h_{ef}$ ) = 2")

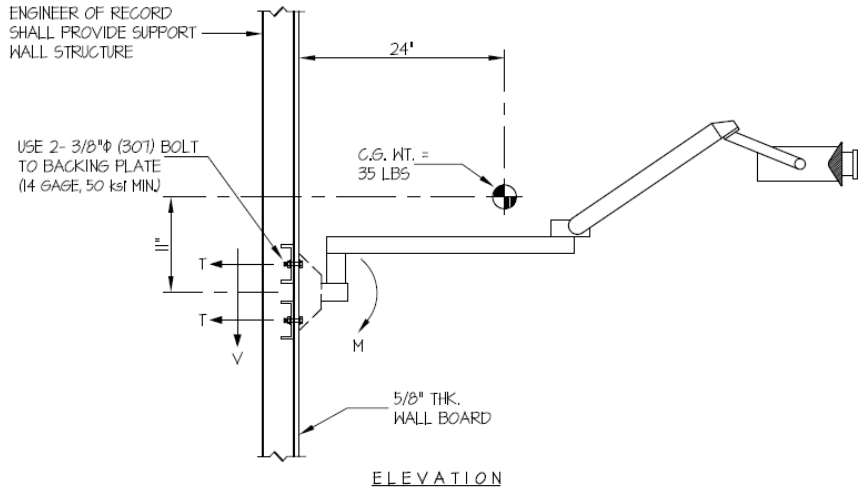
CONCRETE WALL

## 6.0 Anchorage & Seismic

### Wall Mount

<b>EASE</b> EQUIPMENT ANCHORAGE & SEISMIC ENGINEERING www.equipmentanchorage.com		
<b>BURTON MEDICAL PRODUCTS</b>  <b>COOLSPOT/OUTPATIENT MINOR SURGERY/ DIAGNOSTIC LIGHTS</b>	DES. J. ROBERSON	SHEET <b>1</b>
	JOB NO. 11-1138	OF <b>2</b> SHEETS
	DATE 6/3/11	

#### SEISMIC ANCHORAGE



$T_{max} = 531 \text{ LBS/BOLT}$   
 $V_{max} = 531 \text{ LBS/BOLT}$

#### NOTES:

1. FORCES ARE DETERMINED PER 2010 CALIFORNIA BUILDING CODE SECTION 1613A AND ASCE 7-05 SECTIONS 12 AND 13. STRENGTH DESIGN IS USED.

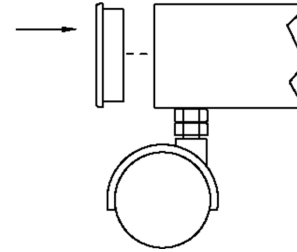
HORIZONTAL FORCE ( $E_H$ ) =  $3.60 W_p$  ( $S_{DS} = 2.00$ ,  $a_p = 2.5$ ,  $I_p = 1.5$ ,  $R_p = 2.5$ )  
 VERTICAL FORCE ( $E_V$ ) =  $0.40 W_p$

2. CENTER OF GRAVITY (C.G.) WEIGHT IS A MAXIMUM. THIS CALCULATION ENCOMPASSES ALL WEIGHTS UP TO THE MAXIMUM WEIGHT SHOWN.

3. ARCHITECT OR STRUCTURAL ENGINEER OF RECORD SHALL PROVIDE SUPPORT STRUCTURE TO SUPPORT WEIGHTS AND FORCES SHOWN.

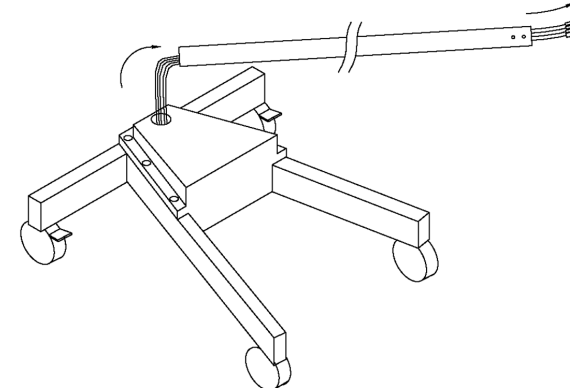


2.2.3 Use a mallet to tap the four (4) black end caps gently into place.



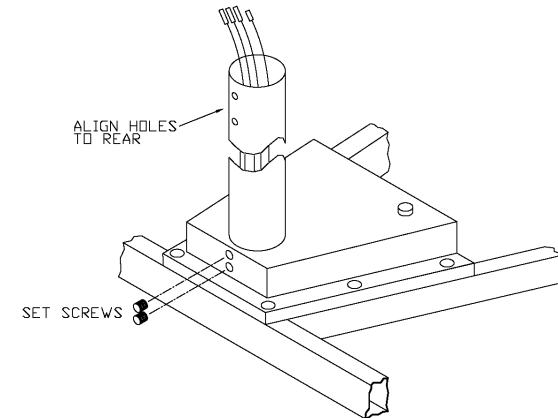
**Figure 3 – Base Leg End Cap**

2.2.4 Run the wire harness coming out the top of the base all the way through the tubular upright. Make sure to insert the wires into the bottom of the tube and bring them out the top. The top of the tube is the end with two holes on one side.



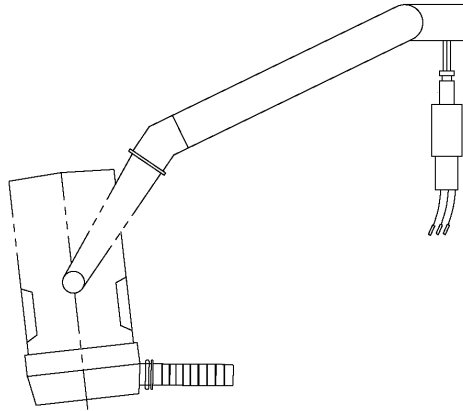
**Figure 4 – Wire thru Upright**

2.2.5 Insert and seat the upright into the base and align the hole to the rear. Secure the tube by tightening the (2) setscrews in the base casting. Make sure that the dog point set screw engages the holes in the tub



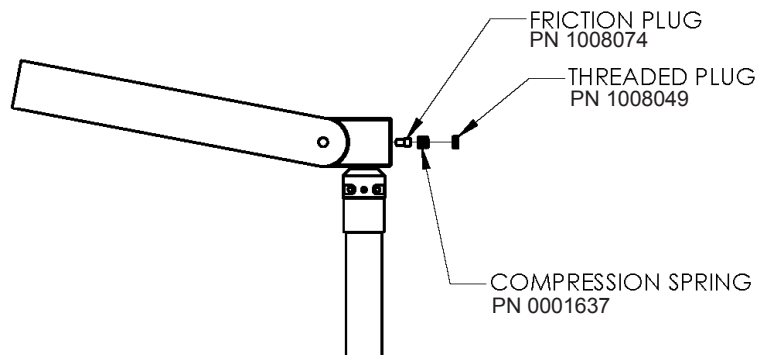
**Figure 5 – Upright to Base**

- 2.2.6 Route the wiring from the head/arm assembly through the pivot support so that all connectors are out the bottom.



**Figure 6 – Wire thru Pivot**

- 2.2.7 Insert the shaft of the pivot support into the mating hole in the articulating arm (Figure 7, next page). You will use the brass friction plug, spring, and threaded plug to retain it, as follows:
- 2.2.8 Insert the brass friction plug into the hole. **Make sure the friction plug is oriented properly to capture the shaft by riding down into the shaft groove** (Figure 8, next page).
- 2.2.9 Insert the compression spring and threaded plug behind the brass friction plug (Figure 8).
- 2.2.10 Screw the threaded plug in until it is flush with the mating surface. It does not require full tightening to hold the pivot support assembly in place.
- 2.2.11 Match the corresponding connectors from the head/arm assembly to the harness in the upright according to color. There will be one (1) unused wire from the upright that can be stuffed back into the tube.



**Figure 7 – Friction Plug**

**NOTE TO QUALIFIED PERSONNEL:**

**All electrical components must be approved for use in accordance with the NEC (United States) or National Canadian Electrical Code (Canada). The installer/technician must be appropriately licensed.**

- 5.2.4 Make the final wiring connections. Secondary wires with quick connects match with corresponding colored wires from the transformer. See wiring diagram in the Instruction for Use and Maintenance manual.

Re-install the bell housing over the casting by sliding it and the collar back up to cover the casting. Hold the bell housing (dome) in place with set screws in the collar.

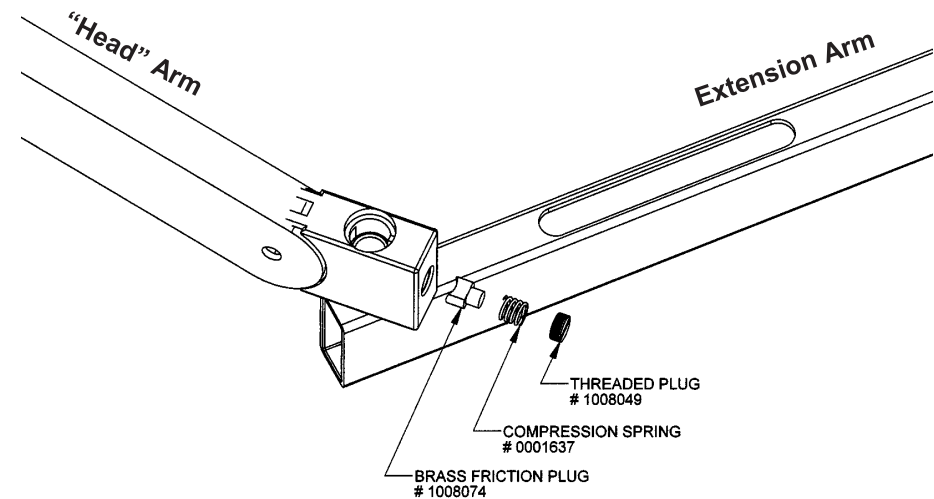
- 5.2.5 Lightly grease the outside of the hollow shaft protruding upward from the end of each extension arm opposite the central pivot support. Use the small green tube of grease in the hardware pack. **Notice that this is the only time that lubricant is applied during the life of the fixture.**

To mate the connectors, run the conductors from each lighthouse through the hollow shaft on the extension arm. Mate the connectors according to color code. You will be able to access the connectors through the slot in the top of the extension arm. Depending on the lighthouse being installed, there may be one or two unused wires, which can be pushed back into the extension arm.

Slide the lighthouse/articulating arm down onto the lightly greased shaft that is on the end of the extension arm.

Retain the articulating arm on the shaft by using the provided friction plug, spring, and threaded plug. Note that the friction plug must be facing in the correct direction to “capture” the shaft by riding into the shaft groove, see Figure 30.

Screw the threaded plug in until it is flush with the mating surface. It does not require full tightening to hold the pivot support assembly in place. It can be tightened for increased friction, if desired, after the overall assembly is complete.



**Figure 30 – Attaching “Head” Arm to Extension Arm**

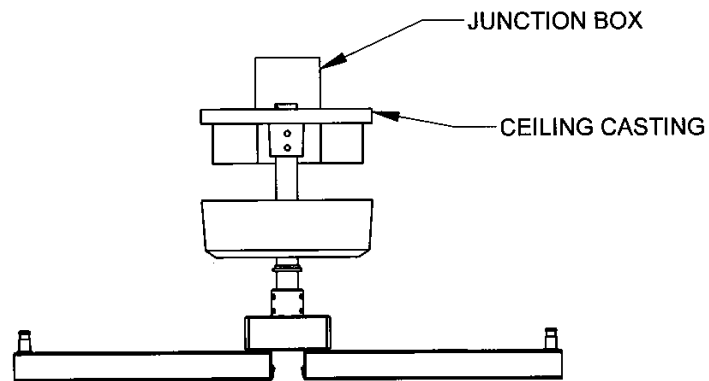
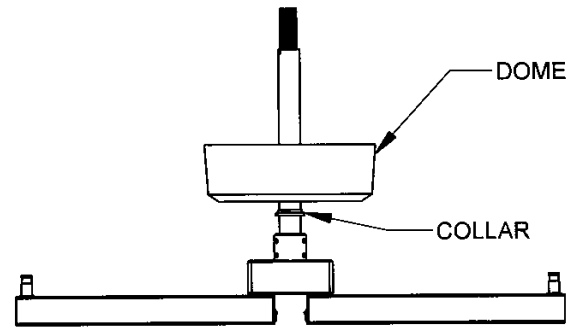
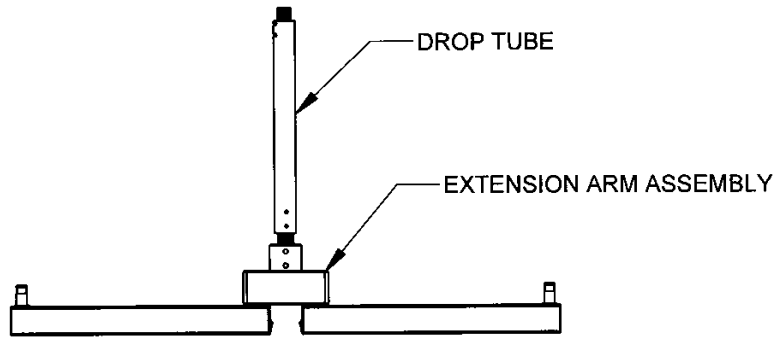


Figure 29 – Downtube, Bell Housing and Ext. Arm

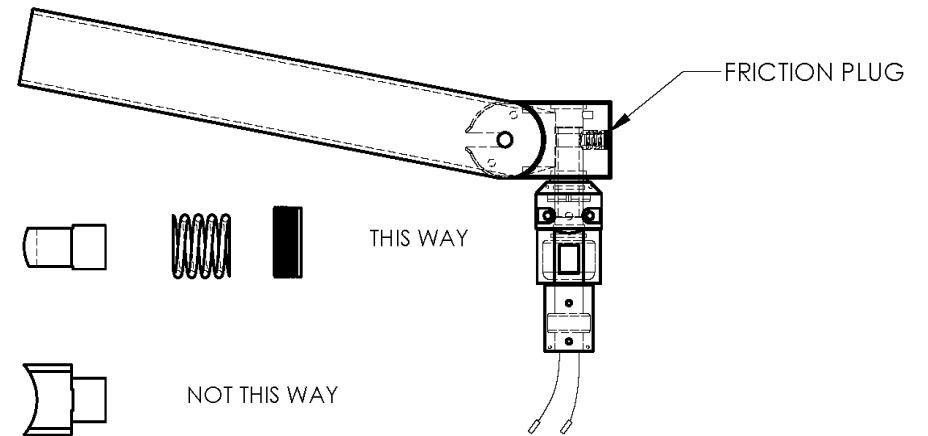


Figure 8 – Orienting the Friction Plug

2.2.12 Orient the head/arm/pivot support assembly to the upright so that the head/arm will hang out over the two base legs. Once in position, the head/arm can't move side to side.

2.2.13 After the proper electrical connections have been made, push the excess harness down the upright, and slide the pivot support onto the upright. Make certain the two holes in the pivot support match the holes in the upright. Fasten the two together with the 8-32 socket-head cap screws provided.

See Figure 9, next page.

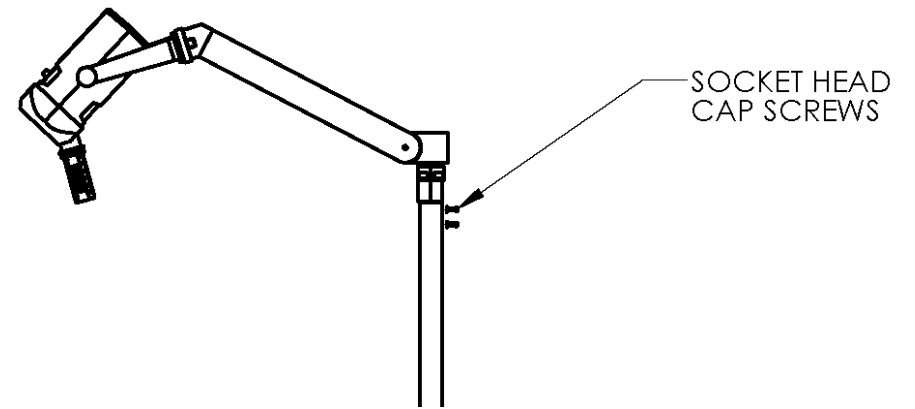


Figure 9 – Attach Head/Arm to Upright

2.2.14 Push the provided hole plug into place on top of the articulating arm. Use a light mallet to tap the hole plug down flush with the top edge of the pivot attachment.

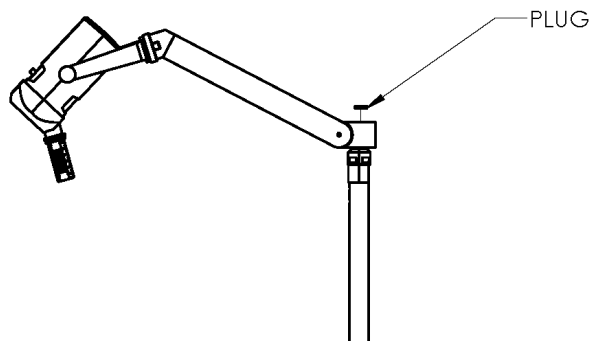


Figure 10 – Inserting Hole Plug in Pivot

2.2.15 Assemble the external friction parts provided in the hardware kit to the articulating arm. Keep parts in the order shown in the diagram. Note that the external friction clip fits between the Belleville washer and the fiber washer.

2.2.16 Energize the light assembly, and turn the switch On to check proper operation. Remember that in order to redirect the light beam right or left, you must rotate the light head about the arm axis, or move the floorstand to the right or left.

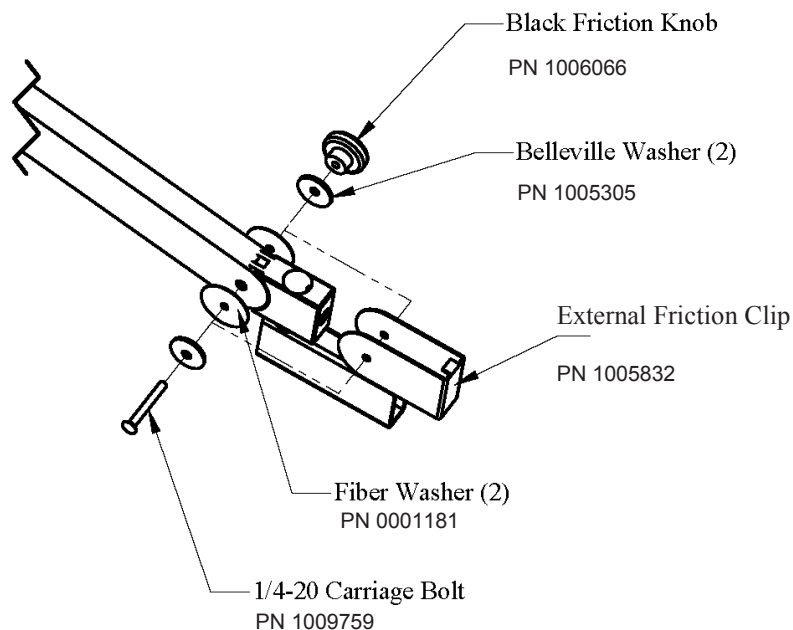


Figure 11 – Assembling Friction Knob and Clip

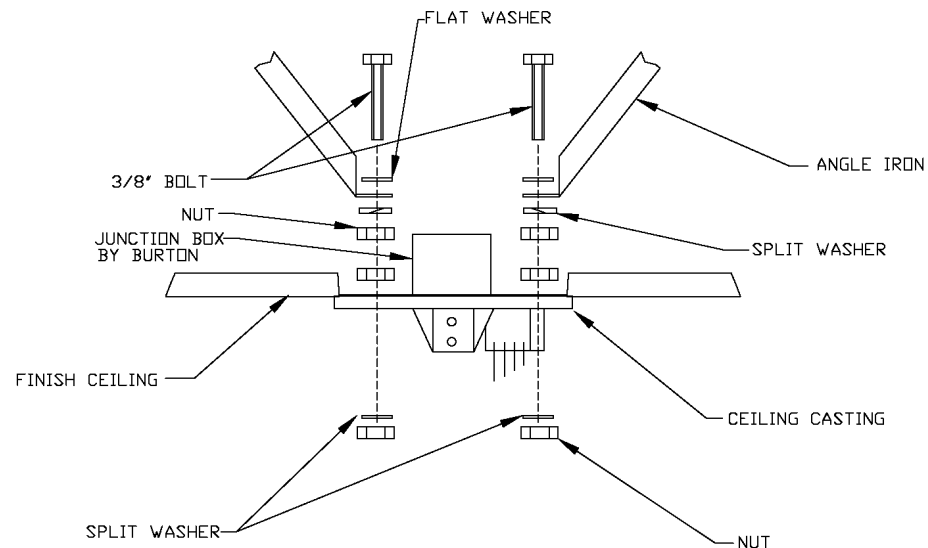


Figure 28 – Ceiling Mount Diagram



**NOTE:** The downtube is pre-cut and pre-drilled at the factory for the average user having an exam room with a 9-1/2 ft. ceiling. The proper height of the light should be determined by the end user. Typically the arms are installed 6-ft 6-in (approximately 78") above the floor. When installed in this "typical" room, there will be approximately 1" of downtube showing above the ceiling plate.

5.2.2 A longer downtube (for higher ceilings) is available on special order. If a shorter downtube is needed, cut the top of the downtube and re-drill the holes, keeping hole size and spacing from the top of the tube the same. The top end of the downtube has three holes, two on one side and one on the other.

Feed the wires from the extension arm up through the downtube, see Figure 29, next page.

Slide the pivot support onto the tube. Make certain the six (6) holes in the pivot support match the holes in the bottom end of the down-tube. Fasten the two together with the 8-32 screws provided.

5.2.3 Slide the collar and bell housing (dome) down the tube, so that it will be out of your way to perform following steps. Temporarily hold the collar in place with set screws.

Slide the downtube up the center hole in the ceiling casting until the top protrudes approximately one inch above the casting. The top hole in the down tube will show just above the ceiling casting. Insert the cotter (or Clevis) pin into this top hole (as in Figure 22).

Fasten the tube securely by inserting the two (2) set screws into the holes in the ceiling casting. Install a dog-point screw in the top hole and a cup-point screw into the bottom hole.

(\*) FURNISHED BY CONTRACTOR

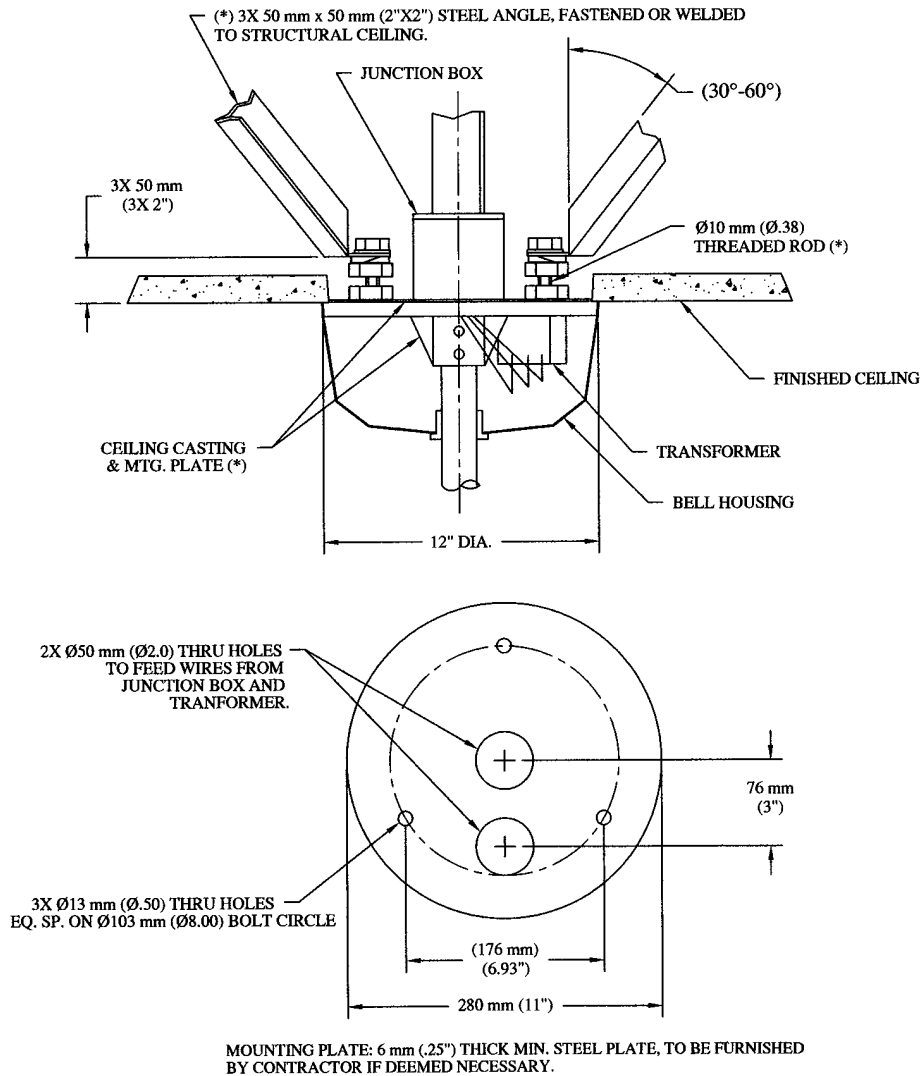


Figure 27 – Ceiling Mount Diagram

### 3.0 Wall Mount Model

#### 3.1 Pre-Assembly

**!** NOTE: Burton recommends that this light be installed by a qualified personnel.

**WARNING:** Failure to properly follow installation and preventive maintenance instructions may result in mechanical failure.



3.1.1 Ensure that the intended electrical outlet is a 3-prong grounded-type, supplying the appropriate voltage. Each light draws 1.4 amps current (Outpatient® II or CoolSpot® II) through the primary circuit.

3.1.2 **NOTE:** The Burton FlexiMount™ wall mounting system has been designed to be used with the Burton Flexible Arm™ lights. These lights are provided as head-and-arm assemblies which are authorized for use only with Burton Flexi Mount™ ceiling mount, wall mount or floorstand. Any other use will void the warranty and may cause a safety hazard.

#### 3.2 Assembly

Tools required:

- Pencil
- Level
- Allen wrench
- socket wrench set
- plastic mallet
- Drill

**!** NOTE: The wall-mounted fixture must be attached to a structurally sound wall that is capable of supporting 200 lbs.

A typical wood frame/drywall room will require the two (2) 3/8" x 3" lag screws provided in the installation kit. However, different mounting hardware may be required for other installation conditions.

3.2.1 Burton recommends a mounting height of 55 to 60 inches (140-152.4 cm) for the wall casting. Locate a stud in the wall closest to the desired mounting spot and, using a level, draw a vertical line on the wall over the stud.

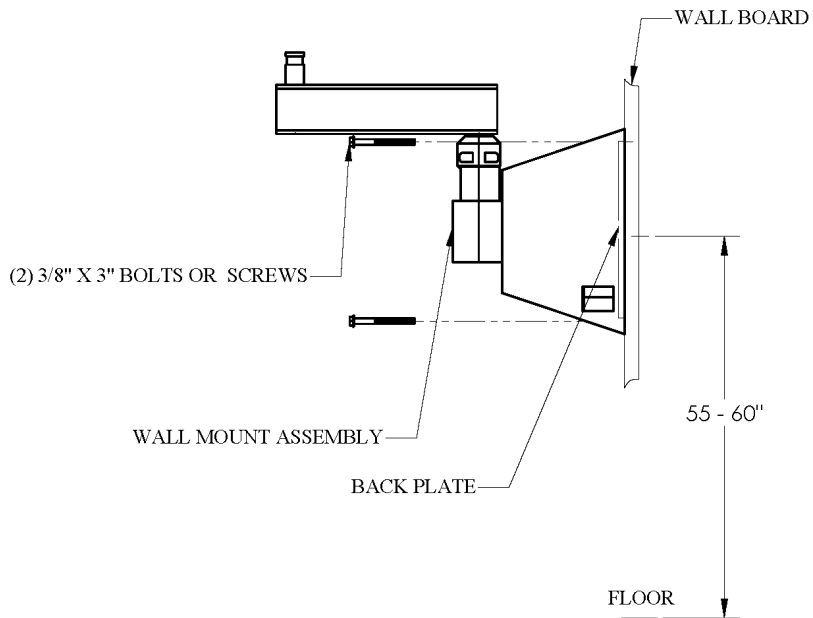
**It is important that this line be perfectly vertical to prevent the light from "drifting".**

3.2.2 Mark the location of the two (2) mounting holes 5.70" center-to-center on the vertical line at the desired height.

Drill two pilot holes of 1/4" diameter at the locations marked on the vertical line. Fasten the wall mount assembly and backplate to the wall with two (2) lag screws (included) or bolts. (Use appropriate hardware depending on whether joists are wood or steel.)

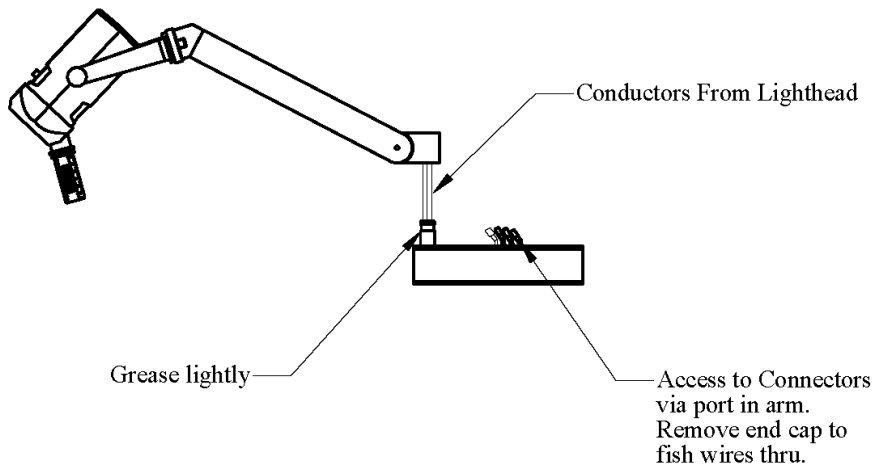
Attach the two (2) decorative covers to the wall mount casting after peeling off the paper backing.

See Figure 12, next page.

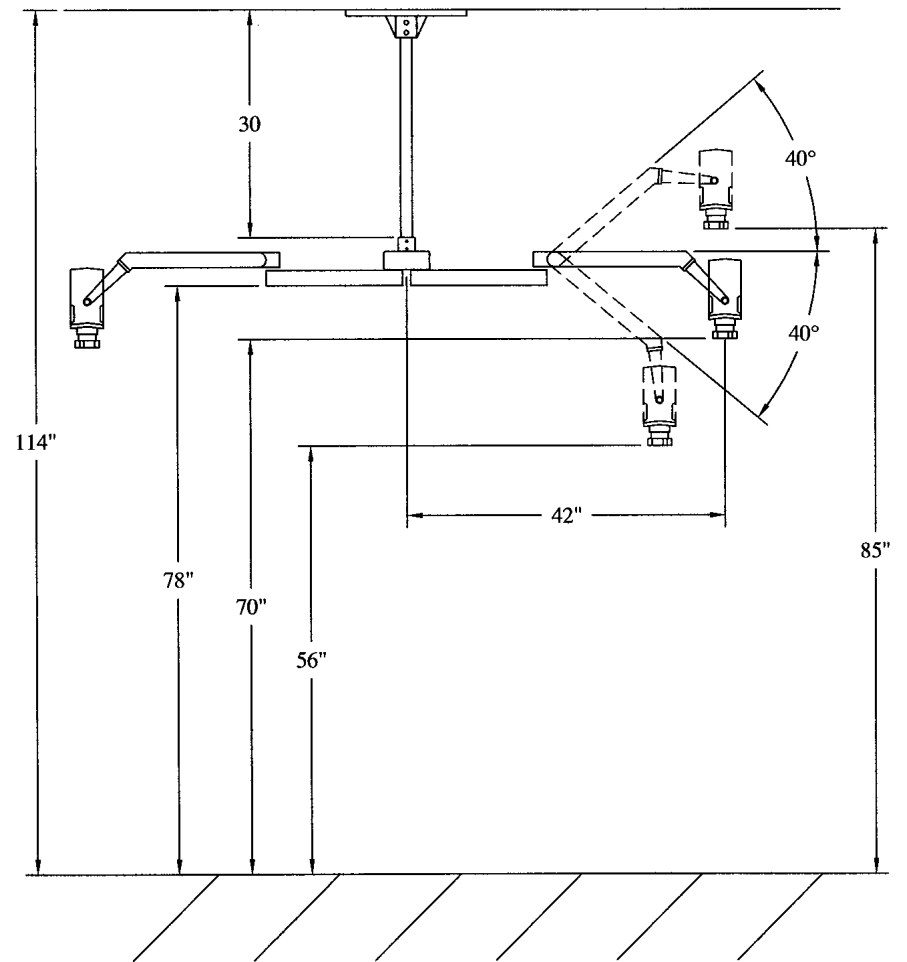


**Figure 12 – Assembling Friction Knob and Cover**

3.2.3 Attach the light head/articulating arm assembly to the extension arm by first mating the connectors. To do this, run the two (2) conductors from the light through the hollow shaft on the extension arm and bring them out through the open top of the extension arm. Mate the connectors according to color code. There will be one or two unused wires (depending on the light fixture) which can be pushed back into the extension arm.



**Figure 13 – Feeding the Conductors & Matching the Connectors**



**Figure 26 – Mounting Height**

## 5.0 Double Ceiling Mount

### 5.1 Pre-Assembly

**NOTE:** Burton recommends that this light be installed by a qualified personnel. It is also recommended that installation be done by two people working together.

**WARNING:** Failure to properly follow installation and preventive maintenance instructions and recommendations can result in mechanical failure.

**NOTE:** The Burton FlexiMount™ ceiling mount systems have been designed to be used with the Burton Flexible Arm™ lights. These lights are provided as head-and-arm assemblies which are authorized for use only with Burton FlexiMount™ Ceiling Mount, Wall Mount or Floorstand. Any other use will void the warranty and may cause a safety hazard.

### 5.2 Assembly

Tools required:

- Drill
- Hacksaw
- Level
- 9/16" open-end wrench
- Wire cutter/ stripper
- Allen wrench
- Small flat-blade screwdriver
- 3 mounting bolts and wire nuts for supply connections.

**NOTE:** To prevent sway and provide proper support to the light, the ceiling mount must be attached to a structurally sound ceiling, which is able to support 400 lbs. Most ceilings will require adequate reinforcing to hold the light. The installing contractor is responsible for providing this reinforcement to suit the individual requirements of each installation. Sway braces (e.g., made of angle iron) are recommended when there are more than 12" between the structural and finished ceilings

The proper height of the light should be set by the end user. Typically the arms are installed 6-ft 6-in (~78") above the floor. This allows the light heads to be adjusted within a vertical range of ~29".

See Figure 26, next page.

5.2.1 Mount the ceiling casting to the ceiling/junction box assembly. Use three (3) 3/8" bolts, split lockwashers, and nuts in a triangular pattern.

See Figures 27 and 28 for details.

3.2.4 Using the small tube of grease in the hardware pack, lightly lubricate the outside of the hollow shaft with grease and slide it into the mating hole in the articulating arm. Note that this is the only time lubricant is ever to be applied to the fixture during its life. Retain the articulating arm by inserting the provided brass friction plug, spring, and threaded plug, in that order.

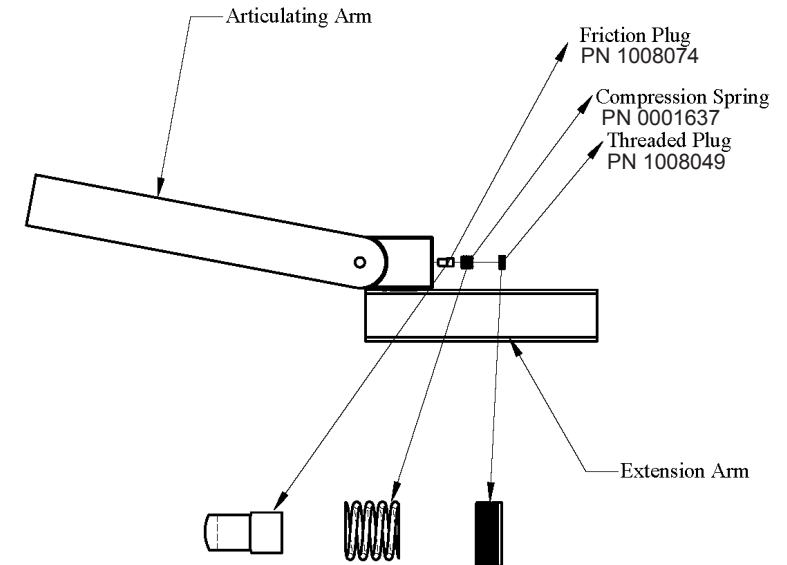


Figure 14 – Inserting Friction Plug

3.2.5 Notice that the friction plug must be oriented properly to “capture” the shaft by riding down in the shaft groove. Then insert the compression spring and screw the threaded plug in until it is flush with the mating surface. The threaded plug does not require full tightening to hold the pivot support assembly in place. It can be tightened for increased friction, if desired, after the overall assembly is complete.

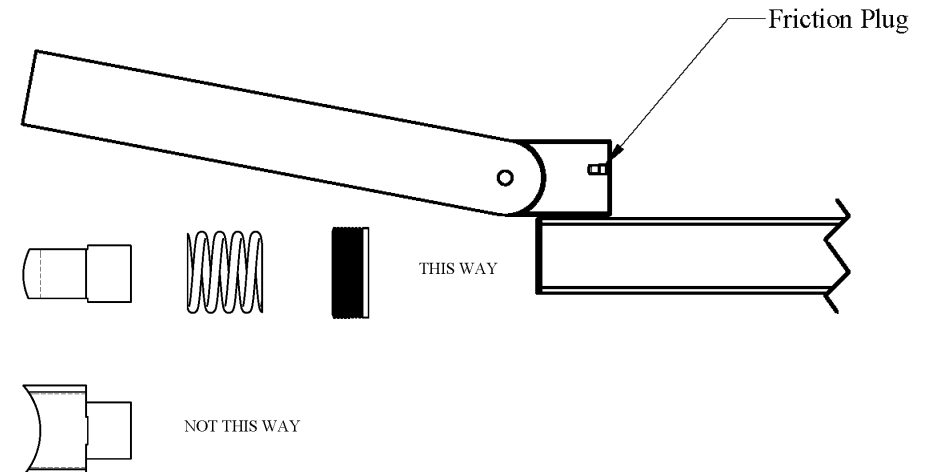
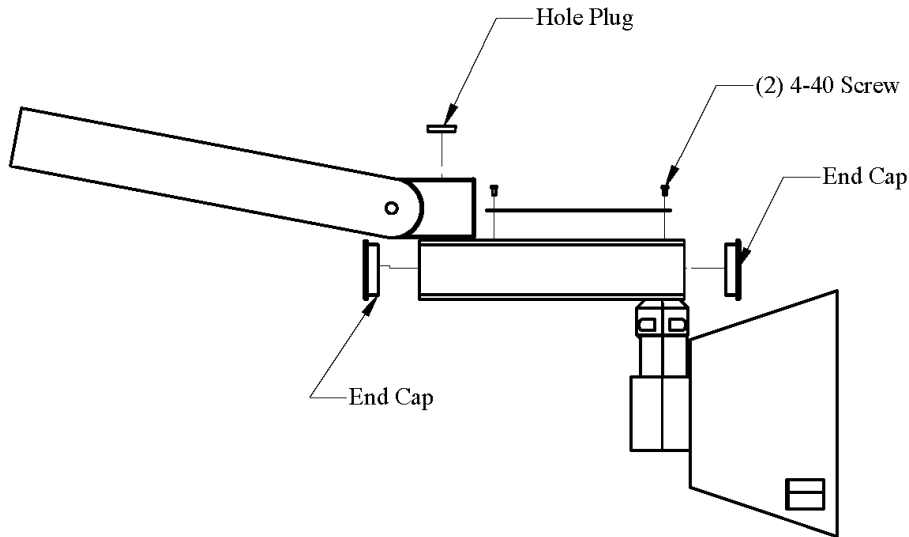


Figure 15 – Orienting the Friction Plug

- 3.3.6 Push the wires back into the extension arm and, using a plastic mallet, gently tap the provided end caps into place.

Also, align the provided hole plug in the hole on the end of the articulating arm. Use a light mallet to tap the hole plug flush with the top edge of the pivot attachment.

Fasten the cover plate to the extension arm using the two 4-40 screws provided.



**Figure 16 – Attaching End Caps**

- 3.3.7 Assemble the external friction parts provided in the hardware kit to the articulating arm. Keep parts in the order shown in the diagram. Note that the external friction clip goes between the Belleville washer and the fiber washer.

Energize the light assembly from a 120V 60Hz source, and turn the switch On to check proper operation.

The extension arm should swing freely horizontally, but have a slight restraining force due to friction of the o-rings in the pivot support. The extension arm should swing back and forth about 180° (limited by the wall).

The articulating arm should move freely up and down approximately  $\pm 40^\circ$ , and horizontally back and forth through 320°. Built-in friction for both vertical and horizontal movement prevents drift of the head/arm.

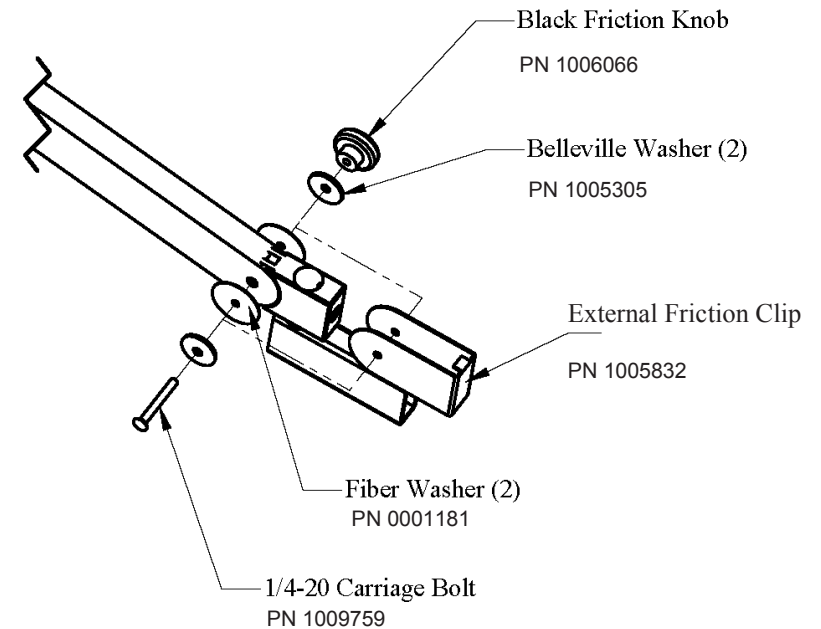
See Figure 16, next page.

- 4.2.7 Assemble the external friction parts and external friction clip provided in the hardware kit to the articulating arm as shown. Keep the parts in the order shown in the diagram. Note that the external friction clip fits between the Belleville washer and the fiber washer.

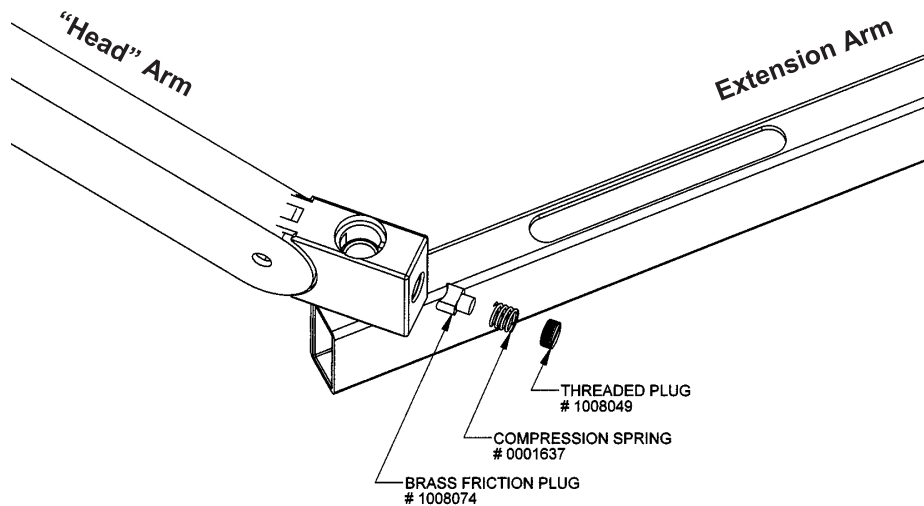
- A.2.8 Energize the light assembly by turning the switch to On to check proper operation.

The extension arm should swing freely horizontally, but have a slight restraining force due to the friction control in the central pivot support. The extension arm should swing back and forth about 360°. It will not swing past 360° because of an internal stop which prevents the internal wiring from becoming tangled.

The articulating arm should move freely up and down approximately 40°, and horizontally back and forth through 340°. Built-in friction for both vertical and horizontal movement prevents drift of the head/arm. Note that the articulating arm will not swing through the center downtube.



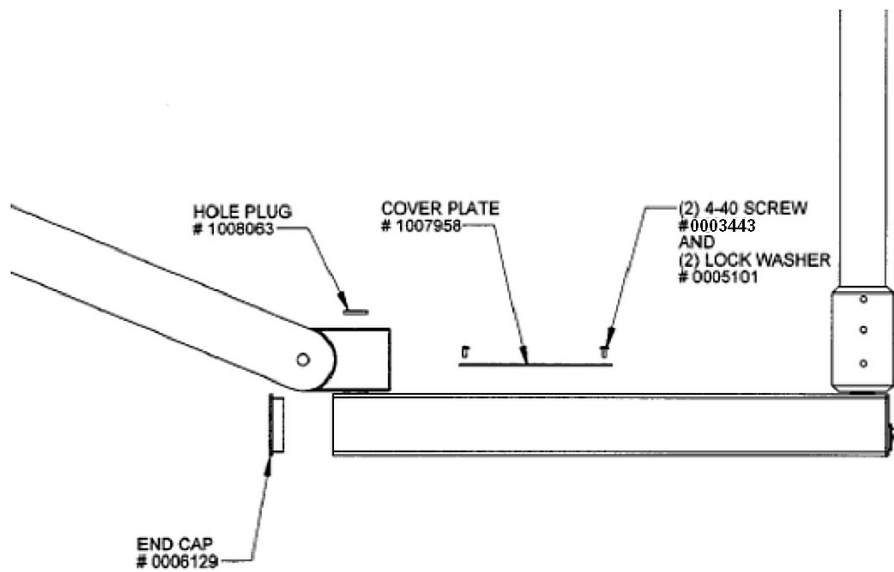
**Figure 25 – Friction Knob and External Friction Clip**



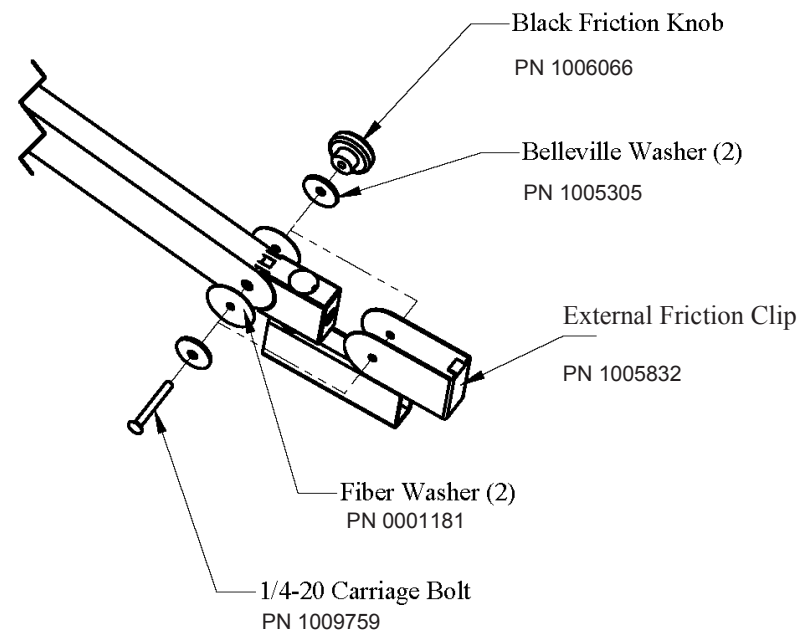
**Figure 23 – Attaching “Head” Arm to Extension Arm**

4.2.6 Push the wires back into the extension arm and, using a plastic mallet, gently tap the provided end caps into place. Also, align the provided hole plug in the hole on the top of the articulating arm. Use a mallet to drive the hole plug flush.

Fasten the cover plate to the slot in the top of the extension arm using the 4-40 screws provided.




**Figure 24 – Attaching End Caps and Cover Plate**





**Figure 17 – Friction Knob and Clip**

## 4.0 Single Ceiling Mount

### 4.1 Pre-Assembly

 **NOTE:** Burton recommends that this light be installed by a qualified personnel. It is also recommended that installation be done by two people working together.


 **WARNING:** Failure to properly follow installation and preventive maintenance instructions and recommendations can result in mechanical failure.

 **NOTE:** The Burton FlexiMount™ ceiling mount systems have been designed to be used with the Burton Flexible Arm™ lights. These lights are provided as head-and-arm assemblies which are authorized for use only with Burton FlexiMount™ Ceiling Mount, Wall Mount or Floorstand. Any other use will void the warranty and may cause a safety hazard.

### 4.2 Assembly

Tools required:

- Drill
- Hacksaw
- Level
- 9/16" open-end wrench
- Wire cutter/ stripper
- Allen wrench
- Small flat-blade screwdriver
- 3 mounting bolts and wire nuts for supply connections.

 **NOTE:** To prevent sway and provide proper support to the light, the ceiling mount must be attached to a structurally sound ceiling, which is able to support 400 lbs. Most ceilings will require adequate reinforcing to hold the light. The installing contractor is responsible for providing this reinforcement to suit the individual requirements of each installation. Sway braces (e.g., made of angle iron) are recommended when there are more than 12" between the structural and finished ceilings

The proper height of the light should be set by the end user. Typically the arms are installed 6-ft 6-in (~78") above the floor. This allows the light heads to be adjusted within a vertical range of ~29".

See Figure 18, next page.

4.2.1 Mount the ceiling casting to the ceiling/junction box assembly. Use three (3) 3/8" bolts, split lockwashers, and nuts in a triangular pattern.

See Figures 19 and 20 for details.

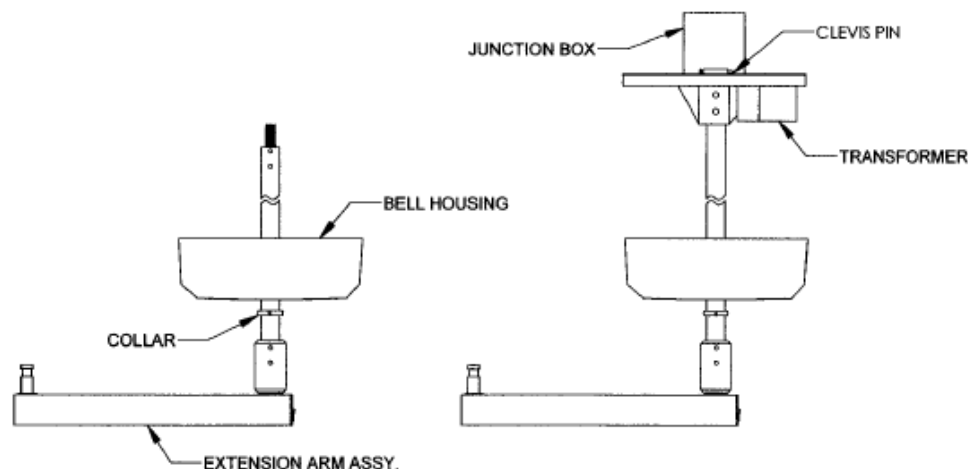


Figure 22 – Assembling the Downtube & Bell Housing

4.2.5 Lightly grease the outside of the hollow shaft that protrudes from the end of the extension arm opposite the pivot support. Use the small green tube of grease in the hardware pack. Note that this is the only time lubricant is applied during the life of the fixture.

Run two or three conductors, depending on what lighthouse is used, from the light head arm through the hollow shaft and into the extension arm. Mate the connectors according to color code. You can access them through the slot in the top of the extension arm. Depending on the lighthouse being installed, there will be one or two unused wires, which can be pushed back into the extension arm.

Push the lighthouse/articulating arm down onto the lightly greased shaft that is on the end of the extension arm.

Retain the lighthouse arm on the shaft by inserting the provided friction plug, spring, and threaded plug in the order shown in the diagram.

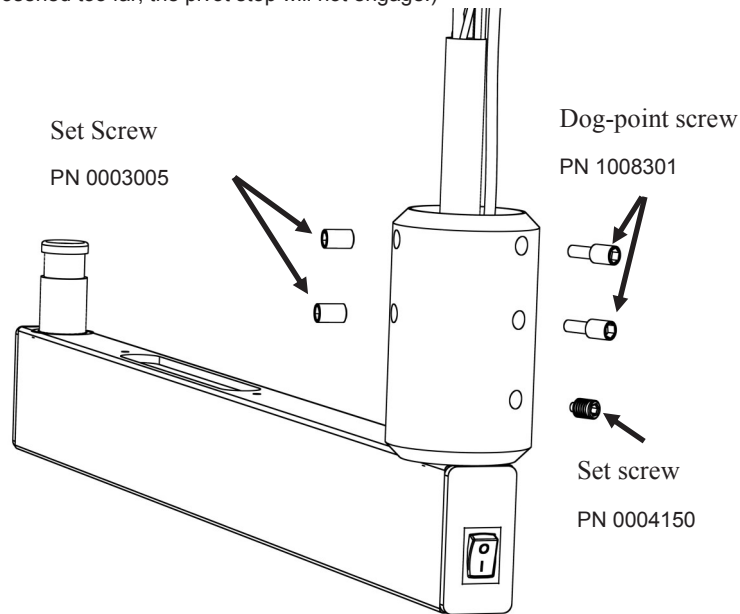
Note that the friction plug must be facing the in correct direction in order to "capture" the shaft by riding down in the shaft groove.

Insert the spring and screw in the threaded plug until it is flush with the mating surface. It does not require full tightening to hold the pivot support assembly in place. It can be tightened for increased friction, if desired, after the overall assembly is complete.

See Figure 23, next page.

- 4.2.3 Re-insert the two dog-point set screws, making sure they engage the mating holes in the downtube. Then secure the extension arm assembly to the down tube by tightening all four set screws (2 dog-point and 2 cup-point).

Although the friction screw is preset at the factory, its setting can be changed in the field to suit the needs of the user. Minor adjustments of the friction screw will control rotational friction of the extension arm about the downtube. (If the set screw is loosened too far, the pivot stop will not engage.)



**Figure 21 – Ceiling Mount Diagram**

- 4.2.4 Slide the collar and bell housing down the tube so that they will be out of your way while you perform the following steps. Temporarily hold the collar in place with two set screws.

Slide the downtube and harness up the center hole in the ceiling casting until the top of the tube protrudes approximately one inch above the casting. The top hole in the downtube will show just above the ceiling casting. Insert the cotter (or Clevis) pin into this hole.

Fasten the tube securely by inserting the (2) set screws into the holes in the ceiling casting. Install a dog-point screw in the top hole and a cup-point screw in the bottom hole.

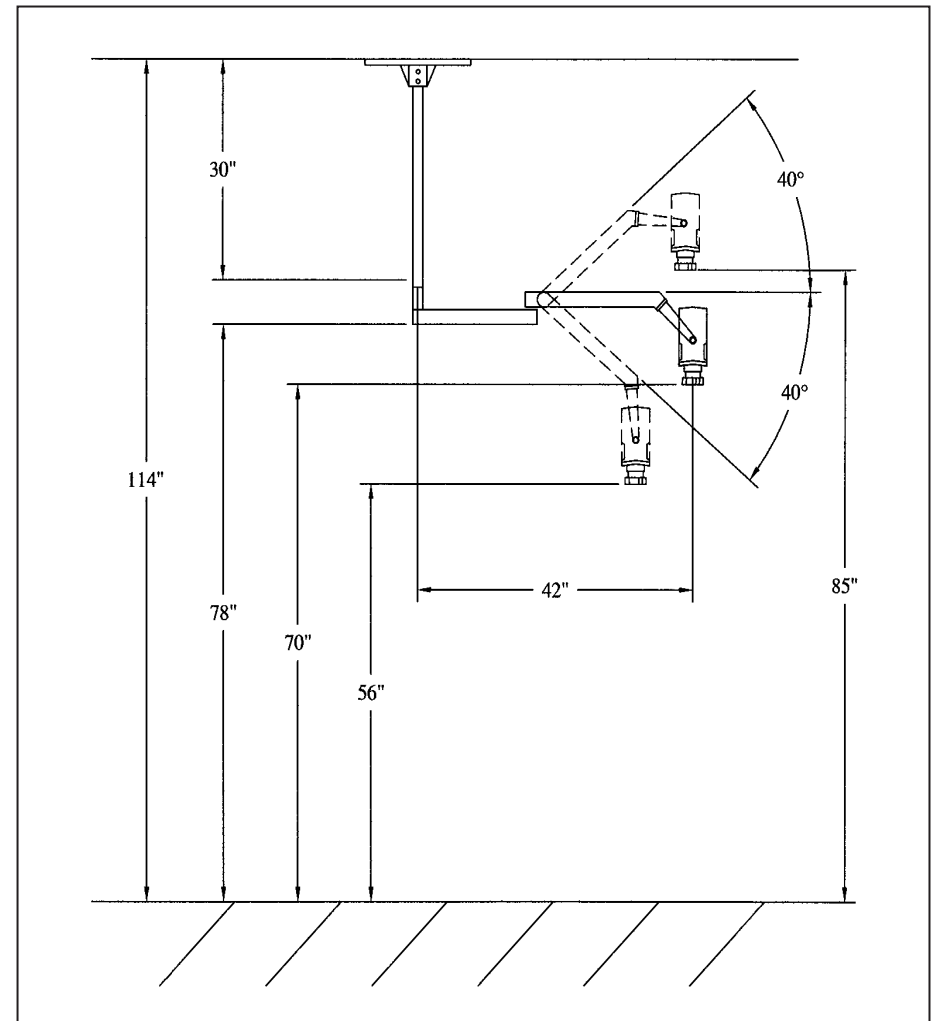
**NOTE TO ELECTRICAL CONTRACTOR:**

**All electrical components must be approved for use in accordance with the NEC (United States) or National Canadian Electrical Code (Canada).**

**The installer/technician must be appropriately licensed.**

Make the final wiring connections. Secondary wires with quick connects mate with corresponding colored wires from the transformer. See wiring diagram(s) in the Instructions for Use and Maintenance manual.

Re-install the bell housing over the casting by sliding it and the collar back up to cover the casting. Hold the bell housing (dome) in place with set screws in the collar.



**Figure 18 – Mounting Height**

(\* FURNISHED BY CONTRACTOR

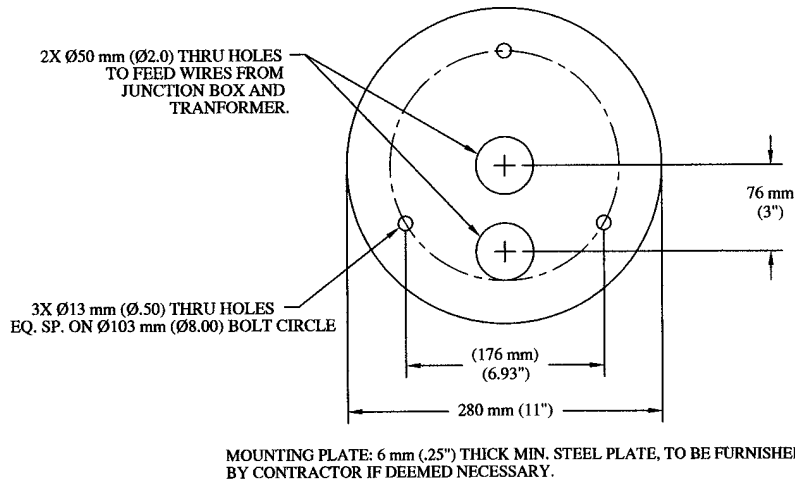
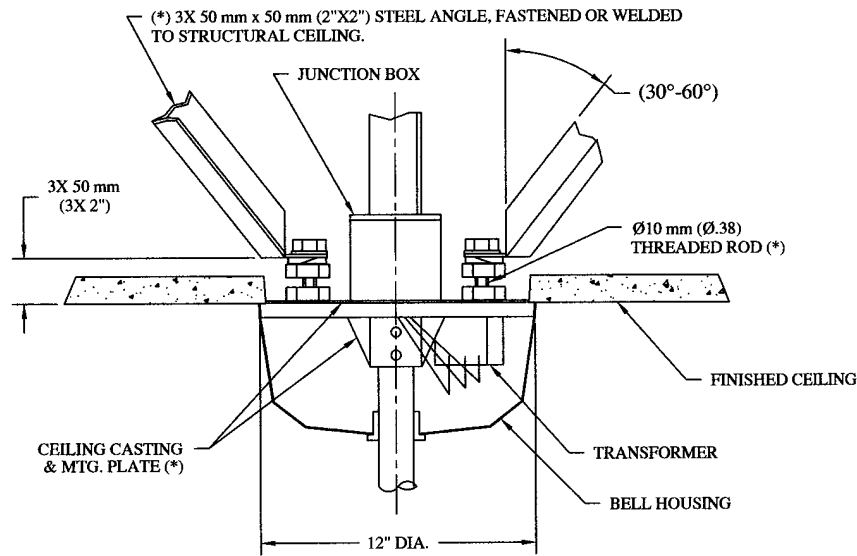


Figure 19 – Ceiling Mount Diagram

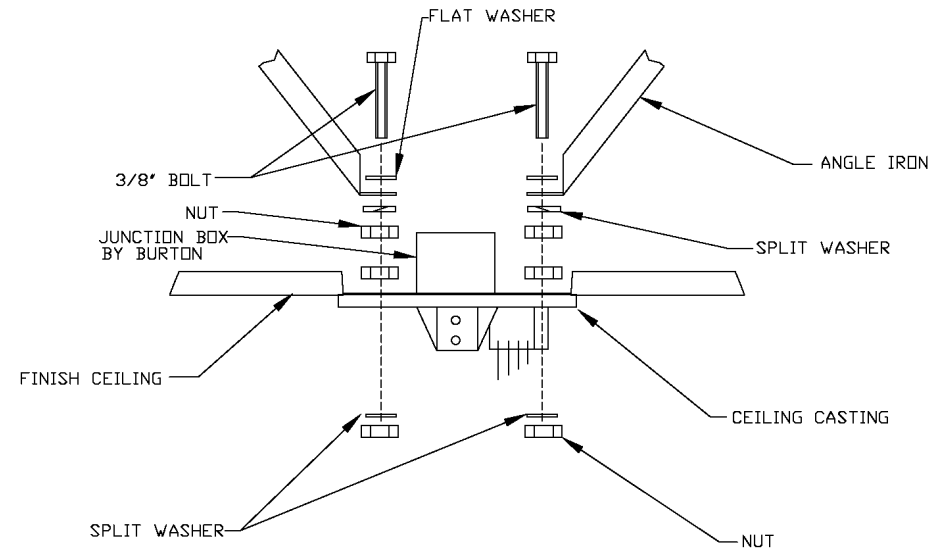


Figure 20 – Ceiling Mount Diagram



**NOTE:** The downtube is pre-cut and pre-drilled at the factory for the average user having an exam room with a 9-1/2 ft. ceiling. The proper height of the light should be determined by the end user. Typically the arms are installed 6-ft 6-in (~78") above the floor. When installed in this "typical" room, there will be approximately 1" of downtube showing above the ceiling plate.

A longer downtube (for higher ceilings) is available on special order. If a shorter downtube is needed, cut the top of the downtube and re-drill the holes, keeping the hole size and spacing from the top of the tube the same. The top end of the downtube has three holes, two on one side and one on the other.

Feed the wires from the extension arm assembly up through the downtube.

4.2.2 The extension arm/pivot support assembly is pre-assembled at the factory. It has five set screws on it, three in one vertical row and two in another:

- The lowest set screw on the 3-screw side is nylon tipped and serves as a friction screw. Do not remove this screw.
- The 2 top set screws on the 3-hole side are dog-point screws. Remove them. You will reinstall them shortly.
- The 2 set screws on the 2-hole side are cup-point screws. Leave them in place. You will tighten them shortly.

Slide the pivot support up over the downtube.